

Fitting Instructions for Air Bag Load Assist Kit

LA16



Make sure your work area is safe and that you do not get under a car that is not properly supported by jack stands etc. Make sure that when undoing suspension components the axle is supported and can not fall.

Read these instructions prior to commencing and learn the tricks the easy way before you need to undo your work.



Air Bag assembly

- **The rings on the air bags do rotate and you will need to align the top and bottom brackets by rotating the rings to ensure there is no twist in the air bag.** With 3 very loose bolts securing each of the top and bottom end plate brackets, it is easiest to rotate the rings by twisting the brackets while there is virtually no clamping pressure. In most cases the chassis and axle run at 90 degrees.
- There are 6 bolts and washers which clamp the bag rings to the end plates. Do NOT tighten 1 bolt all the way up and then the next as the bags wont sit straight inside the rings. Start by doing every second bolt to finger tight, then the alternate bolts. Then tighten the first 3 to semi tight, then the alternate 3, then tighten each set 2-3 more times, alternating so even pressure is applied as you go. There is no need for extreme tightness. The rubber of the bag acts just like an O'Ring and virtually never leaks and does not need extreme tightness.
- Once tightened any curves or waves in the end of the bags are flattened out and do not cause leaks.
- Most kits come with the air fittings already seated into the end plates. If you need to fit the air fittings a sealant is needed, despite there being what appears to be a white or grey thread seal on the fitting.
- When cutting air lines, make sure you do not squash the air line in the process. You must not use side cutters, pliers or scissors. If you use a saw, make sure you remove 100% of debris inside hose as that can cause leaks in valves. The best cutting devices are the hose cutters we provided for free or a knife. Make sure ends are straight 90 degrees.

Fitting brackets to vehicle — do ONE side at a time.

1. Remove the rubber bump stop from chassis.
2. Slide the pre-assembled bag assembly into place.
3. Line up the lower bracket so the bag sits straight and mark where the 8mm hole needs to be drilled in the bump pad. (refer to illustration)
4. Bolt the top bracket into place using the original bump stop bolts and mounting points.
5. Bolt the lower bracket in place using your new hole.
6. Sometimes you need to lower the vehicle and pump up the bags with air to fully reach and prevent a stretched bag from preventing mounting bolts to tighten.
7. Tighten the U bolts and top mounts.
8. Make sure nothing fouls with the air bag such as sway bar brackets, mounts for brake lines or breathers etc and remember the bags get wider as they compress.
9. Pump bags temporarily up to 80+ psi to bed them in and the rings "Bite" into the rubber flanges of the bags. Don't drive at such high pressure just do it as a bedding in process.

Trouble shooting

You should not have leaks and can expect air to remain in the bags for a few weeks without refilling. It is near impossible to find a leak if it takes more than 3 days to leak out and only replacing fittings or refitting bags until the leak stops can solve such slow leaks. But if you have a bag that deflates in say less than 2 days then we stand a good chance of finding the leak. Start by pumping the bag with as much air as possible like 100+ psi (pretty much until compressor stops pumping) – the bags are good for 1,000+ psi and you won't hurt them but don't drive with this extreme pressure for the sake of your chassis and handling. At extreme pressure air should be wanting to escape quickly. With a spray bottle (or a plastic drink bottle with small hole drilled in cap) spray soapy water on the bag and on all fittings. It is rare to find a leak in a bag and more common to find a leak in a valve or where the air line goes into a fitting or around the thread of a fitting in an end plate. After a few minutes a small bubble might appear and show you the leak. Leaking fittings can be taken apart and cleaned out. Often a bit of dirt can cause the leak – a drop of oil and a blow of compressed air through the fitting can be a great way to clean out a fitting or valve.

By the way AAA Suspension use 6mm air hose and all threads are BSP type.



The air bags and brackets in this kit are built to be super strong. In some cases stronger than your car. Do not carry extreme loads and travel at high speeds with high pressure as hitting holes and dips at speed with extreme loads could result in damage to your vehicle. This is an overloading issue and by being sensible you will avoid damage.

Do not exceed your vehicle's GVM (Gross Vehicle Mass). Your GVM will be detailed on your vehicle compliance plate. Know your limits with regard to loads carried or towed.

If you remain within your load limits, drive at a safe speed for the conditions and run your air bags at an ideal working pressure below 60 psi you will have trouble free travelling.

The good thing about air bag suspension is you can just keep adding more air to suit your preferred ride height and loads carried. Typically a good working pressure is 25 to 50 psi per bag. The bags become your bump stops. When unloaded you may run the bags empty but a few psi will cushion your bump stop and offer a bit of added stability to your handling.



Air Assist kits come with a 5 year parts replacement warranty on bags, brackets and air fittings. Keep a copy of your invoice or online purchase so you can show us later when you purchased your kit.

- Warranties are parts replacement only and exclude postage, labour and any other incidental cost or damage.
- Warranties also exclude corrosion or damage caused by external influences such as road hazards, heat, chemicals, salt or fuel spills.

It is the fitter's and ultimately the owner's responsibility to make sure there is no rubbing and adequate clearance to tyres, exhaust, brake lines, etc.

The brackets in this kit are proudly made in Australia



LA-16

FORD RTV ONLY

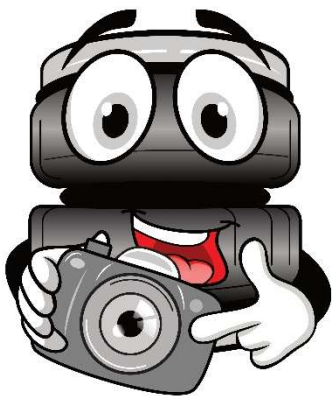
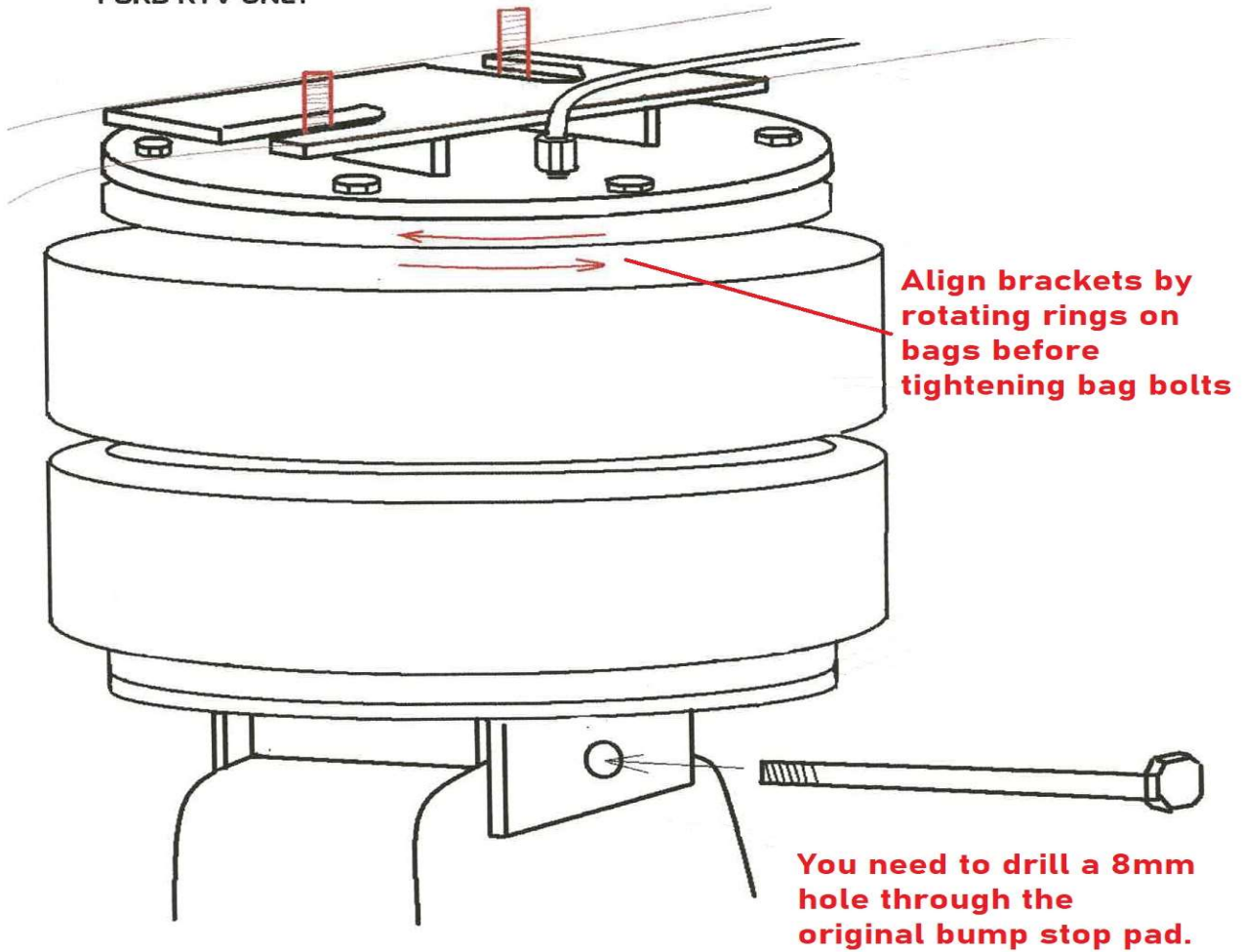

One thing we really struggle with is obtaining photos of our kits out in the real world. If you can send us some pics of your kit fitted and maybe some pics of your vehicle carrying a load with and without air in your bags to demonstrate their effectiveness, we would most certainly appreciate that.

And you know we also just like seeing all the varied places and applications our bags are used.

Please email all pics to steve@aaasuspension.com.au

Feel free to call us at any time for support – 1300 396 892.

Thanks,

AAA Suspension

